

Force Sensor Applications

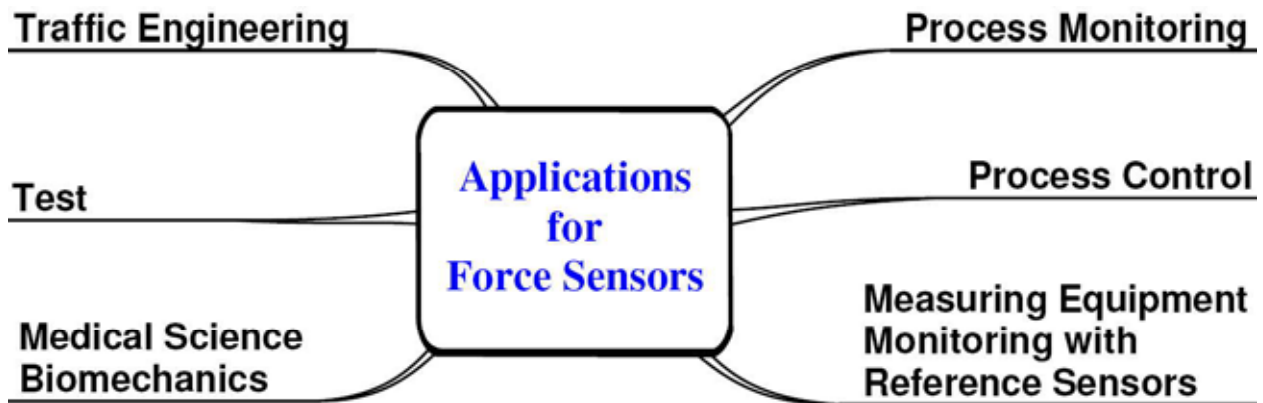

Process Monitoring

Press Force Measurement

e.g. Pressing of pills in the Pharmaceutical Industry

A pelleting tool, consisting of a matrix with a top punch and a lower punch, is used for the production of pills.

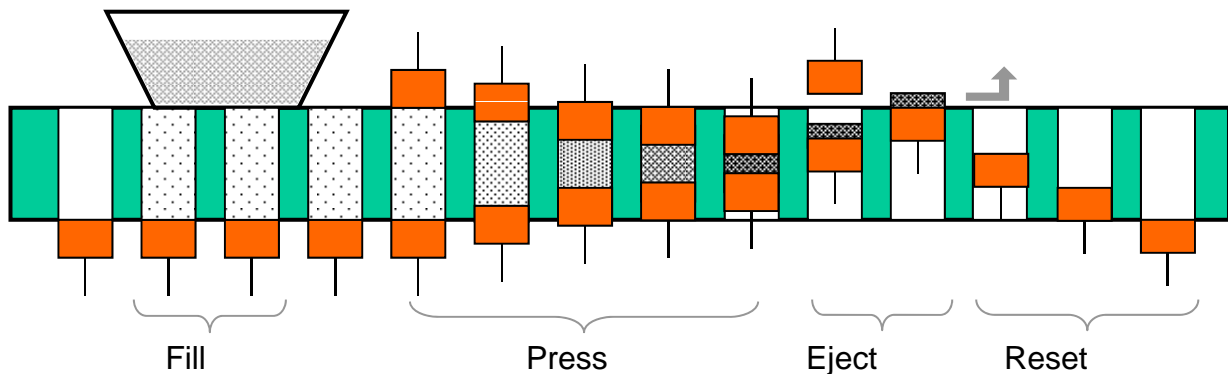
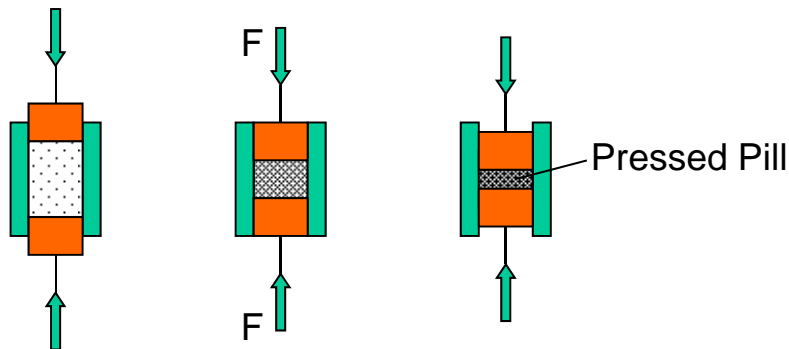

Compression: schematic process in a rotation pill press

Press forces up to 20 kN → Overload stability up to 50 kN

Ejection of the pill approx. 200 N

Average compressive stress in the pill

$$\sigma_i = \frac{F}{A} \cdot \frac{1}{(1 - \varepsilon)}$$

with

F
A
ε

Press force
Cross section surface
Porosity

Process Monitoring

- **Joining Processes**
- **Rivets**
- **Press-in force of bolts, caps, ball bearings etc.**



K2392 range 2 kN

Subsequent examination is hardly possible (destruction)

Determination of the max. value of the press-in forces
Statistical analysis of the measurement results
Computation of the process capability C_{pk} -value

Process Control

Production Processes

- Extruder screw-conveyor
(problem: temperature)
Measurement takes place in the gear

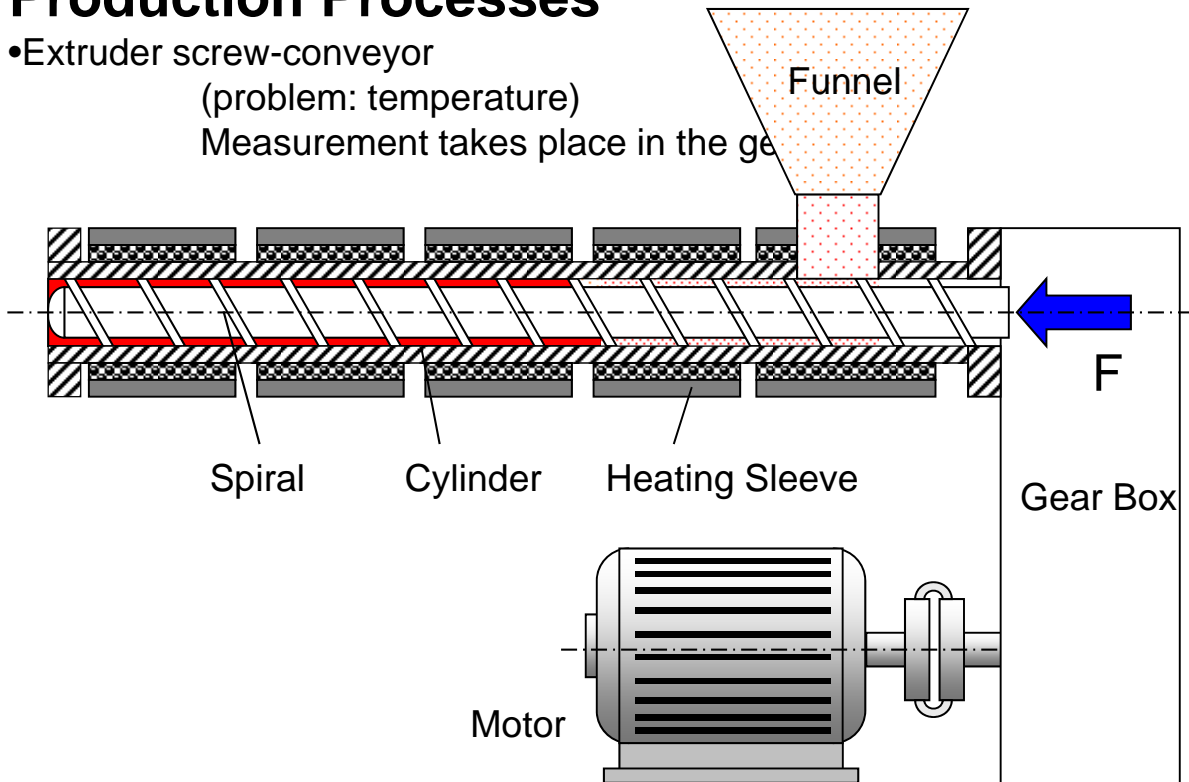

Constant spiral back-pressure
Thus max. possible ejection at same quality

Regulation by motor rotation speed



Process Control

Web Tension

- Conveyor-belts
- Printing presses

- Minimum maculature
- Prevention of web tears
(clotted incoming end → engine damage)

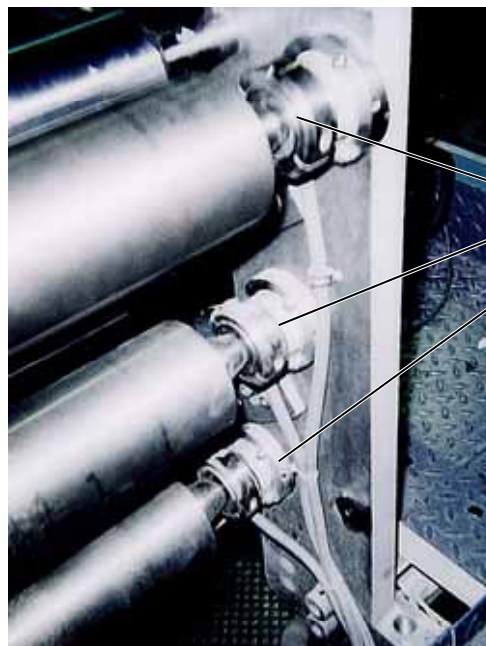

K 2148

Literature: Zitt, H.: Simulation von Bahnspannung und Tänzerbewegung beim Transport von Materialbahnen. MATLAB select 2001, Heft 1, S. 9-11



Measurement Equipment Monitoring with Reference Sensors

Sensor Calibration

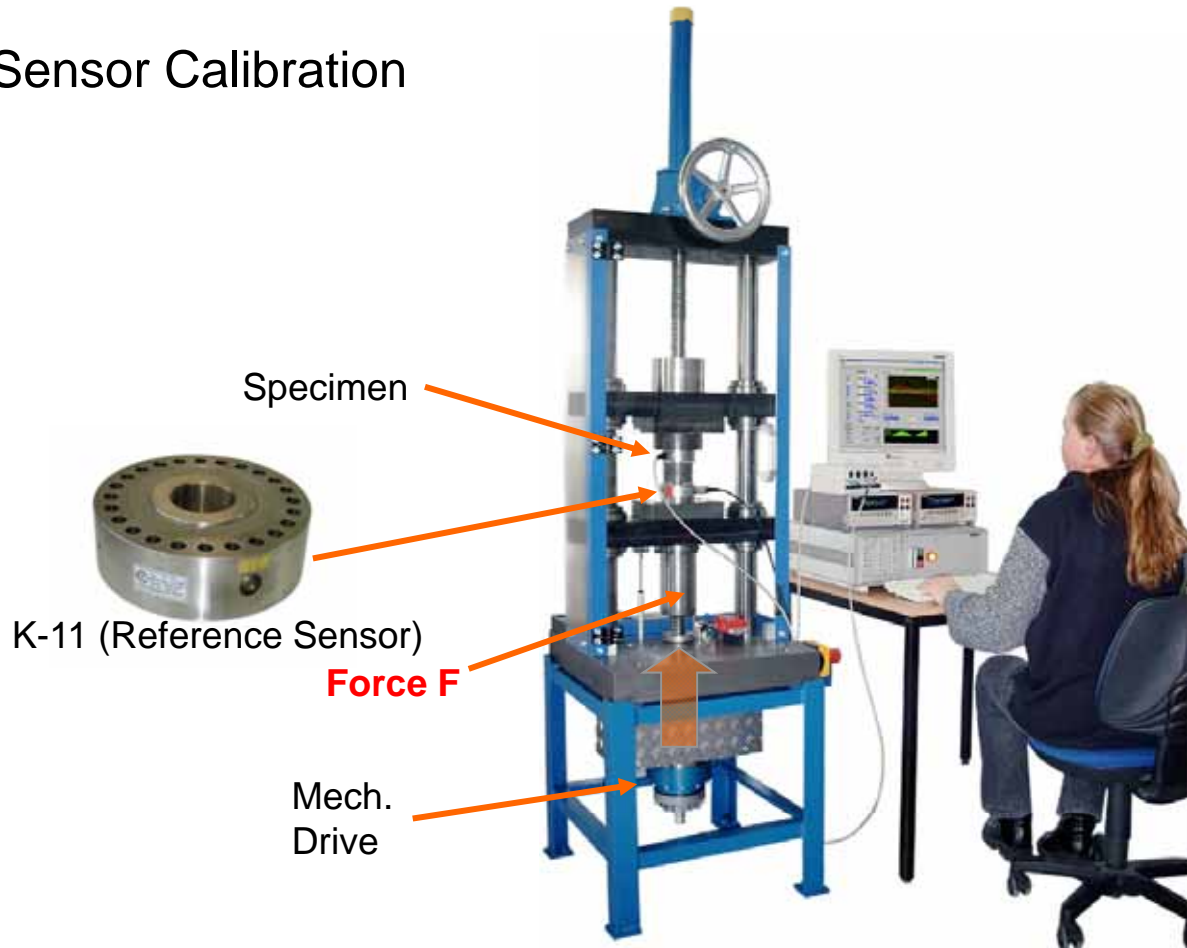

Calibration of Force Sensors
Adjustment of Force Sensors

Medical Science Biomechanics

Dynamometry

Leg Force Measurement



Medical Diagnostics
Sports Medicine

Hand Force Measurement



Measurement of the Hand Force:

The handgrip force is basis for dressing, eating, cooking etc.

Reduced handgrip force → reduced muscularity
(e.g. used for elderly people)

For example, measurement of the hand force after an injury of the hand shows considerably smaller values (comparison between injured and healthy hand)

Test

Force Measurement during Product Development



Drive

Spindle

Force Sensor K-11

Spring

Counter Bearing



- Determination of the Spring Characteristic

Test

Preload Force Measurement for Screw Joints (Screw Testing)

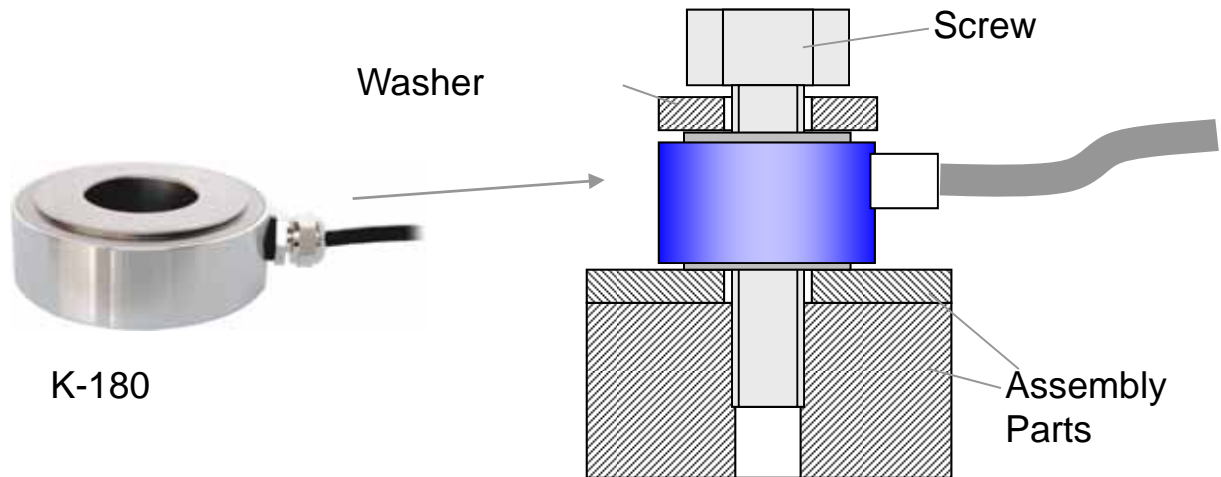

- Determination of the **Clamping Force** in Screw Joints
- Fit Performance** of the Screw Joints by long-term observance (soft separating layers e.g. gaskets etc. cause permanent deformation)



- Determination of Tightening Directions**
Concurrent measurement of torque and angle of rotation.

- Washer to avoid damage of the force sensor
- The washer should have grounded surfaces
- If necessary provide a grounded washer on the assembly part side as well



Test

Material Test Methods

Destructing Test Methods

- Tension Test – Rupture Test
- Compression Test
- Bending Test
- Shear Test
- Torsion Test

Slightly Destructing Test Methods Hardness Testing

Material Test Methods Non-Destructive Test Methods

Examinations with Ultrasonic, X-
Radiation



5 MN – Test Machine

Example Tensile Strength Testing Machine

The Force Sensor is used
for the checking of the
device or for the direct
force measurement



Traffic Engineering

Rail Monitoring

Preload of the Connection

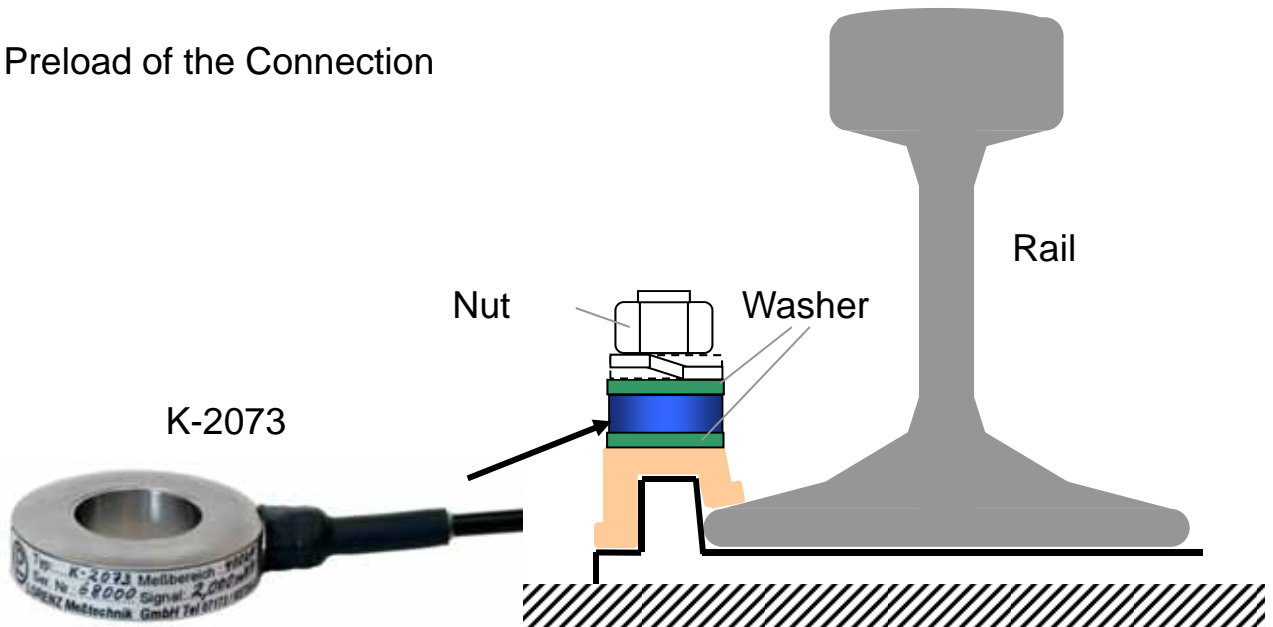

Preload at the frog of the switch

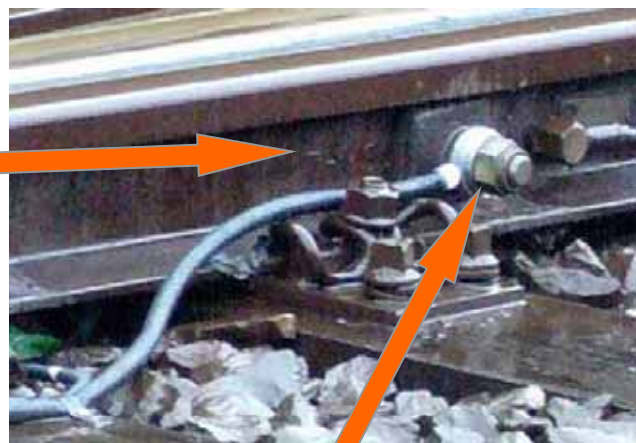

- Intense loaded range
- Measurement at fastening bolt
- Early detection of damages



K-2073

Traffic Engineering

Switch Monitoring

Force Measurement during the switch-change-over-process

Result of the resistance force measurement at switchblades

- Stiffness of the switchblade
- Contact pressure of the switchblade
- Friction of the guides
- Lubrication
- Abrasion

